



FRIGGI
SOTAAB

FRIGGI
SOTAAB®

ALUMINIUM CUTTING SOLUTIONS



SOITAAB | FRIGGI

Per un **Gruppo industriale italiano** essere un **leader riconosciuto nel mercato internazionale** significa saper coniugare tradizione pluriennale, sviluppo tecnologico, affidabilità, creatività, ricerca sui materiali, qualità nel servizio e la capacità di porre al centro di tutto sempre e comunque l'esigenze del cliente. È così che SOITAAB, da molti anni, ottiene **successi in ogni continente**, producendo e distribuendo macchine da taglio a CNC e Segatrici a Nastro.

SOITAAB cura con **estrema attenzione** ogni aspetto della filiera industriale, nel rispetto di una produzione e di un know how completamente Made in Italy; il **nuovo moderno stabilimento di Milano** dispone di un'area espositiva permanente al servizio dei suoi operatori e clienti provenienti da tutto il mondo per qualsiasi richiesta di prove di taglio e dimostrazioni dal vivo. SOITAAB è un'azienda **certificata ISO9001**.

L'UNIONE FA LA LEADERSHIP

Il Gruppo SOITAAB ha acquisito nel 2010 definitivamente il **know-how** ed il marchio di **FRIGGI, leader di settore e massimo esempio di tecnologia ed esperienza italiana applicata alle soluzioni di taglio riconosciuto in tutto il mondo**.

Con questa operazione **FRIGGI-SOITAAB** diventa in assoluto uno dei maggiori costruttori mondiali di segatrici e, per know how e tradizione, il riferimento primario per le macchine di grandi dimensioni.

Il Gruppo SOITAAB produce ora le **nuove segatrici a nastro a marchio FRIGGI-SOITAAB**, con ampliamento continuo di modelli e **sviluppo di nuove tecnologie**.

SOITAAB | FRIGGI

For an **Italian Industrial Group** to be a recognized **leader in the international market** means knowing how to combine long-term tradition, technological development, reliability, creativity, materials research, quality of service and the ability to place always at the center of its attention the customer's needs.

In this way SOITAAB, for many years, gets **success in every continent**, producing and distributing CNC cutting machines and band saw. SOITAAB cares with **extreme caution** any aspect of the industrial chain, in respect of a production and knowhow entirely Made in Italy; the **new modern factory in Milan area** with a permanent exhibition and show room welcomes all domestic and international dealers and customers for any need of demonstration or cutting test. SOITAAB is an **ISO9001 certified** company.

UNION IS LEADERSHIP

SOITAAB Group has acquired, in 2010, the **know-how** and trademark of **FRIGGI, leader and a true example of Italian technology and experience applied to cutting solutions recognized worldwide**.

In this way **FRIGGI-SOITAAB** becomes absolutely one of the world's leading manufacturers of band saws and, for know-how and tradition, the absolute reference for large dimension machines.

SOITAAB Group now produces **new bandsaws branded FRIGGI-SOITAAB**, with continuous expansion of models and **development of new technologies**.

TECHNOLOGIES

We are constantly developing innovative technologies in order to obtain high cutting performances.



TURNABLE BLADE-GUIDE
0°-90° Turnable blade-guide



HIGH SPEED CUTTING
Blade speed up to 3000 mt/min



SURE LOCK SYSTEM
Strong clamping devices



360° TURNTABLE
Great advantage for molds makers. Up to 9 cuts with a single set-up



T-LOAD SYSTEM
Working table designed for different loading operations: Crain, Forklift ecc.



ANTI-VIBRATIONS
Avoid vibrations on metal sheets during the cutting operation



ACTIVE FEEDING CONTROL
Auto-controlled feeding technology. It ensures high accuracy during all cutting operations



HMI SYSTEM always connected
New Human Machine Interface
WIFI - remote - MES ready -
Db real time video service



ALUMINIUM VERSION
Blade speed from 300 to 1200 mt/min



CURVE CUTTING TECHNOLOGY
Make curve cutting on big size material as sheets and blocks. Available on VAS OSF & GANTRY models



SMART TABLE
Integrated spheres system that allow an easily material handling. Only on VTS model



ANTI JAMMING SYSTEM
It prevents locking of the blade during slabs cutting operations

ALUMINIUM CUTTING SOLUTIONS

	SV 640 TS VERTICALE A TAVOLA SCORREVOLE VERTICAL - SLIDING TABLE	
	VTS VERTICALE A TAVOLA SCORREVOLE VERTICAL - SLIDING TABLE	
	VAS OSF ALL VERTICALE ARCO SCORREVOLE AUTOMATICA - TAGLIO 0°-90° + CURVO VERTICAL - MOVING HEAD - AUTOMATIC CUT 0°-90°	
	VAS L HS VERTICALE AD ARCO SCORREVOLE CON RISCONTRO INTERNO AUTOMATICO VERTICAL MOVING HEAD WITH AUTOMATIC INSIDE FEEDER	
	2MF HS ACN ORIZZONTALE AUTOMATICA - SEMIAUTOMATICA HORIZONTAL - AUTOMATIC - SEMI AUTOMATIC	
	ONL ALL ORIZZONTALE AUTOMATICA - SEMIAUTOMATICA HORIZONTAL - AUTOMATIC - SEMI AUTOMATIC	
	2MF TS HS ORIZZONTALE A TAVOLA SCORREVOLE HORIZONTAL - SLIDING TABLE	
	GANTRY HS ORIZZONTALE A PORTALE MOBILE HORIZONTAL - MOVING HEAD	
	2MF COILS ORIZZONTALE A TAVOLA SCORREVOLE HORIZONTAL - SLIDING TABLE	

SV 640 TS

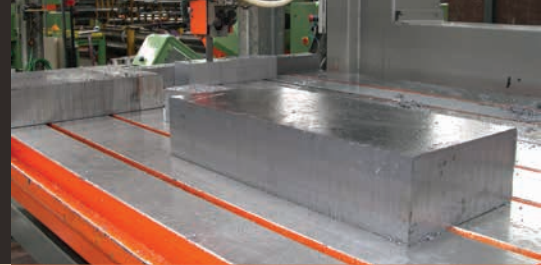

Segatrice verticale a tavola mobile adatta ai più svariati campi di impiego, semplice e flessibile.

Il taglio avviene grazie al movimento della tavola che scorre su 3 guide lineari ed è azionata da vite e motore brushless.

È possibile tagliare materiali con forma ortogonale senza staffaggio. La tavola mobile è dotata di cave a "T" secondo norme ISO che consentono un comodo staffaggio di qualsiasi materiale anche di forme non regolari.

Robustezza e tecnologia all'avanguardia sono le caratteristiche principali di questa macchina, le prestazioni sono di alto livello, sia con lame bimetalliche che in metallo duro.

The SVTS is a vertical bandsaw with a moving table for use in varying applications; flexibility and simplicity at its best.

The material works its way through the saw by way of a moving table that runs along 3 linear way guides, driven by ballscrew and brushless motor. **It is possible to cut irregular shapes with or without the use of clamping.**

The table features "T" slots that allow for convenient clamping of any material, even irregular shapes.

The overall robust build and advanced technology are the main features of this machine. Expect optimum performance both with bimetal and carbide blades.

HIGH LIGHTS

- Facilità di carico/scarico materiale
- Taglio multiplo
- Recupero scarti
- Quick setup, loading/unloading
- Multiple cuts
- Scrap removal system

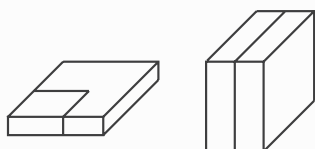

SV 640 TS ALL

SV 640 TS C 1200

SV 640 TS C 2200

CAPACITÀ DI TAGLIO (verticale) / CUTTING CAPACITY (vertical)	600 mm	600 mm
CAPACITÀ DI TAGLIO (sbraccio) / CUTTING CAPACITY (throat)	600 mm	600 mm
CORSA TAVOLA / TABLE STROKE	1200 mm	2200 mm
DIMENSIONE LAMA / BLADE DIMENSION	5480x41x1,3	5480x41x1,3
VELOCITÀ LAMA / BLADE SPEED	300÷1200 m/nim	30÷1200 m/nim
POTENZA MOTORE LAMA / BLADE MOTOR POWER	9,5 kw	9,5 kw
PESO / WEIGHT	3100 kg	3500 kg





Segatrice a nastro a tavola mobile dedicata al taglio di lastre di alluminio di spessori elevati.

Completamente automatica, consente la programmazione di tagli in misura permettendo di completare il lavoro senza la presenza dell'operatore. Il sistema di sfere idrauliche a scomparsa nella tavola (SPH), permette la movimentazione manuale del materiale con grandissima semplicità, consentendo di effettuare tagli trasversali e longitudinali. La ridotta altezza del piano di lavoro consente all'operatore una confortevole movimentazione del pezzo.

Disponibile anche con uno speciale variatore di velocità per il taglio di titanio e super leghe.

This bandsaw features a moving table designed specifically for cutting large aluminum plate.

Completely automatic and programmable; once programmed the machine will run without operator assistance. The table-top is equipped with hydraulic spheres resulting in extremely easy movement and positioning of material allowing for both transversal and longitudinal cuts. The reduced work table height also makes it easy on the operator for movement and positioning of material.

Optional variable blade speed is available for cutting titanium and exotic alloys.

HIGH LIGHTS

- Facilità di carico/scarico materiale
- Taglio multiplo in automatico
- Possibilità taglio tondi
- Sfere tavola
- Taglio asciutto
- Cave x muletto
- Riscontro mobile
- Range di velocità lama x Titanio e Alluminio
- Lame carbide
- Ease of material loading/unloading
- Fully automated and programmable
- Ability to cut round material (optional)
- Table-top spheres
- Dry cut system
- Cut-out for forklift loading
- Loadable back guage
- Blade speed range for titanium and aluminum
- Hard metal blades

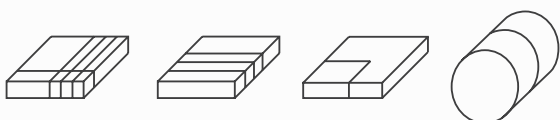

VTS

3000X1500X600

4000X1500X600

CAPACITÀ DI TAGLIO (verticale) / CUTTING CAPACITY (vertical)	600 mm	600 mm
CAPACITÀ DI TAGLIO (sbraccio) / CUTTING CAPACITY (throat)	1500 mm	1500 mm
CORSA TAVOLA / TABLE STROKE	3000 mm	4000 mm
DIMENSIONE LAMA / BLADE DIMENSION	8700x41x1,3 mm	8700x41x1,3 mm
VELOCITÀ LAMA / BLADE SPEED	300 ÷ 1200	300 ÷ 1200
POTENZA MOTORE LAMA / BLADE MOTOR POWER	7,5 kw	7,5 kw
PESO / WEIGHT	10900 kg	12400 kg



4100X1500X1150

4100x1500x1500

1150 mm

1500 mm

1500 mm

1500 mm

4100 mm

4100 mm

9700x41x1,3 mm

9950x54x1,3

300 ÷ 1200

300 ÷ 1200

9,5 kw

9,5 kw

14400 kg

18500 kg

VAS OSF ALL

La grande competenza tecnica e progettuale maturata in decenni di esperienza ci ha permesso di dare vita ad una grande segatrice automatica realizzata appositamente per il taglio di lastre di **alluminio e leghe aeronautiche quali titanio, inconel e astelloy**.

Grazie al sofisticato e robusto guida-lama rotante, è possibile tagliare sia in senso trasversale che in senso longitudinale senza riposizionamento del pezzo. Inoltre la macchina è dotata di uno speciale bloccaggio con morse che consentono il taglio di più lastre sovrapposte.

Decades of experience and research in sawing technology and technical expertise has enabled us to give life to a large sawing machine designed specifically for cutting **aluminum plates and aerospace alloys such as titanium, inconel and hastelloy**.

The sophisticated and robust, rotating blade guide system allows you to cut both vertically and horizontally without repositioning the material; rip and strip. A huge savings in operator time and material handling costs. This machine is also equipped with vertical locking vises that allows cutting of multiple plates at one time.

HIGH LIGHTS

- Cross cutting
 - Guida-lama rotante
 - Bloccaggio verticale
 - Velocità lama x acciaio, titanio, alluminio
 - Lame carbide
 - Rulli guidavamo - sistema anti-vibrazione lamiera
 - Morse indipendenti
- Cross cutting
 - Rotating blade guides
 - Vertical vises
 - Dedicated blade speed for steel, titanium, aluminum
 - Hard metal blades
 - Anti-vibration guides
 - Independent vise operation

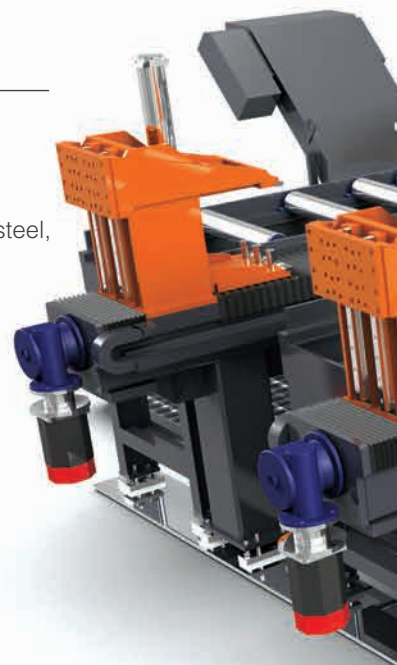

VAS OSF ALL

6250X300X2000

8250X300X2000

CAPACITÀ DI TAGLIO (verticale) / CUTTING CAPACITY (vertical)	300 mm	300 mm
CAPACITÀ DI TAGLIO (sbraccio) / CUTTING CAPACITY (throat)	2000 mm	2000 mm
CAPACITÀ DI CARICO / LOADING CAPACITY	6250x300x2500	8250x300x2500
CORSA ARCO / HEAD STROKE	6250 mm	8250 mm
DIMENSIONE LAMA / BLADE DIMENSION	9360x41x1,3 mm	9360x41x1,3 mm
VELOCITÀ LAMA / BLADE SPEED	300÷1200 m/nim	300÷1200 m/nim
POTENZA MOTORE LAMA / BLADE MOTOR POWER	18,5 kw	18,5 kw
PESO / WEIGHT	30500 kg	44600 kg



VAS L HS



Segatrice verticale ad arco scorrevole e tavola fissa con riscontro automatico interno destinata al taglio di grandi lastre. La posizione del robusto riscontro mobile, garantisce un libero accesso alla tavola facilitando il carico/scarico del materiale, sia dall'alto che mediante carrelli elevatori.

La struttura compatta e robusta ottenuta grazie all'esperienza acquisita negli anni garantisce affidabilità, grandi prestazioni ed una estrema semplicità di utilizzo della macchina.

The VAS LHS is a vertical, high-speed bandsaw with a moving head and fixed worktable and automated backgauge that is ideal for cutting large aluminum plates.

The design and location of the backgauge allows for easy access to the worktable when loading and unloading material either by forklift or overhead crane.

The VAS LHS has an overall compact and robust design. Thanks to decades of experience in sawing technology and technical expertise, this machine delivers high-performance with complete ease of operation.

HIGH LIGHTS

- Alta velocità di taglio
- Facilità di carico/scarico materiale
- Lame carbide
- Struttura compatta e robusta
- Riscontro posizionatore con pinza
- High speed
- Simple to operate
- Hard metal blades
- Robust and heavy-duty structure ideal for heavy
- Movable work-gauge with clamping device

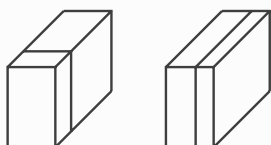

VAS L HS

4000x2000x1200

CAPACITÀ DI TAGLIO (verticale) / CUTTING CAPACITY (vertical)	1200 mm
CAPACITÀ DI TAGLIO (sbraccio) / CUTTING CAPACITY (throat)	2000 mm
CORSA ARCO / HEAD STROKE	4000 mm
DIMENSIONE LAMA / BLADE DIMENSION	13.550 x 54 x 1,6 mm
VELOCITÀ LAMA / BLADE SPEED	300 – 3000 m/min
POTENZA MOTORE LAMA / BLADE MOTOR POWER	54 Kw
PESO / WEIGHT	31.800 Kg



2MF HS ACN

Novità per il 2016, questa segatrice orizzontale a due montanti a ciclo automatico per taglio di barre è destinata a lavori dove è richiesta una elevata produttività. Fornisce prestazioni all'avanguardia abbinate ad una estrema precisione di taglio anche negli impieghi più gravosi. La discesa dell'arco avviene per mezzo di cilindro idraulico controllato da valvola proporzionale, assicurando alta precisione di taglio in ogni condizione.

Questa segatrice è il nuovo punto di riferimento nel proprio segmento e racchiude i valori tipici della nostra tradizione: durata, affidabilità, alte prestazioni unite ad un basso costo per taglio.

New for 2016, this dual-column, horizontal and fully automatic bandsaw, is designed for high speed cutting where high volume output is required. It provides leading-edge performance and extreme cutting accuracy even under the toughest conditions. This machine features a hydraulic head feed controlled by a proportional valve and high speed technology.

This bandsaw is the industry leader in its segment and contains the typical values of our tradition; durability, proven performances, incredible accuracy and a low cost per cut.

HIGH LIGHTS

- Velocità di taglio fino a 3000 m/min
- Facilità di carico/scarico materiale
- Taglio multiplo in automatico
- Lame carbide
- Nuovo pannello HMI con connessione wifi
- High speed cutting - up to 3000 m/min
- Easy loading / unloading operations
- Automatic working cycle
- Hard metal blades
- New HMI control with wifi connection

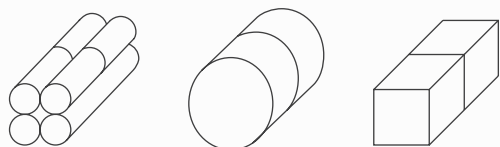

2MF HS ACN

400

600

CAPACITÀ DI TAGLIO / CUTTING CAPACITY	400 mm	600 mm
DIMENSIONE LAMA / BLADE DIMENSION	9.200x34x1,1 mm	16.776 x 54 x 1.6 mm
VELOCITÀ LAMA / BLADE SPEED	300÷3000 m/min	300÷3000 m/min
POTENZA MOTORE LAMA / BLADE MOTOR POWER	45 kw	54 kw
PESO / WEIGHT	9500 kg	12500 kg





800

800 mm

17.740 x 54 x 1.6 mm

300÷3000 m/min

60 kw

18000 kg

ONL ALL



Segatrice orizzontale a due montanti a ciclo automatico per taglio di barre destinata a lavori dove è richiesta una elevata produttività.

Fornisce prestazioni all'avanguardia abbinate ad una estrema precisione di taglio anche negli impieghi più gravosi.

La discesa dell'arco avviene per mezzo di cilindro idraulico controllato da valvola proporzionale.

ONL ALL racchiude i valori tipici della nostra tradizione: durata, affidabilità, alte prestazioni unite ad un basso costo per taglio.

This dual-column, horizontal and fully automatic bandsaw is designed for cutting solid bars or bundles where high volume output is required. It provides leading-edge performance and extreme cutting accuracy even under the toughest conditions. This machine features a hydraulic head feed controlled by a proportional valve.

These are the attributes that place this bandsaw as an industry leader in its segment. The ONL horizontal bandsaw contains the typical values of our tradition; durability, proven performance, incredible accuracy, and a low cost per cut.

HIGH LIGHTS

- Range velocità di taglio ottimale per alluminio - ALL
- Facilità di carico/scarico materiale
- Taglio multiplo in automatico
- Lame carbide
- Nuovo pannello HMI con connessione wifi
- Cutting speed for aluminum - ALL
- Easy loading / unloading operations
- Automatic working cycle
- Hard metal blades
- New HMI control with wifi connection

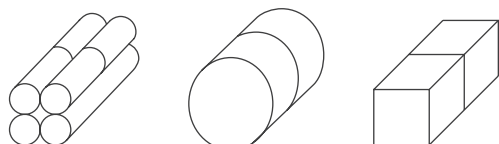

ONL ALL

460

560

CAPACITÀ DI TAGLIO / CUTTING CAPACITY	460x460 mm	560x560 mm
DIMENSIONE LAMA / BLADE DIMENSION	8470x41x,1,3 mm	8660x41x1,3 mm
VELOCITÀ LAMA / BLADE SPEED	300÷1200 m/min	300÷1200 m/min
POTENZA MOTORE LAMA / BLADE MOTOR POWER	11 kw	11 kw
PESO / WEIGHT	7800 kg	8500 kg



660

800

660x660 mm

800x800 mm

9470x54x1,3 mm

12050x54x1,3 mm

300÷1200 m/min

300÷1200 m/min

18,5 kw

18,5 kw

13500 kg

16000 kg

2MF TS HS

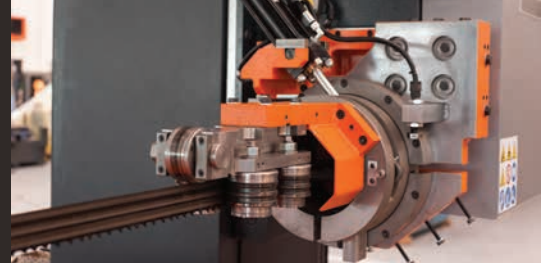

Progettata per il taglio ad alta velocità degli slabs di alluminio, 2MF TS HS è il risultato di vent'anni di innovazioni nelle soluzioni di taglio per alluminio.

La capacità di questa macchina di tagliare sia in verticale che in orizzontale, la rende ideale per il taglio di grandi blocchi di alluminio e lingotti.

Il portale fisso e la tavola mobile consentono di effettuare più tagli senza spostare il materiale, semplificando e riducendo drasticamente la movimentazione dei materiali e i tempi di set-up.

Designed for HIGH SPEED CUTTING plates out of aluminum slabs, the 2MF TS HS is the results of twenty years of innovations in aluminum cutting solutions.

This machine's ability to cut in both the vertical plane and horizontal plane, makes it the ideal machine for cutting large aluminum blocks and ingots.

The fixed head and the moving table allows for the possibility of making several cuts without moving the material, thereby simplifying and drastically reducing material handling.

HIGH LIGHTS

- Ottima finitura di taglio
- Tolleranze precise
- Velocità di taglio fino a 3000 m/min
- Lame carbide
- Guida-lama rotante 0°-90°
- Sistema di serraggio materiale
- Supporto rialzato per carico materiale
- Allineamento preciso del materiale
- Sistema frenatura volani
- Taglio asciutto
- Excellent cut piece
- Tight tolerances
- High speed cutting - up to 3000 m/min
- Hard metal blades
- Rotating blade guides 0°-90°
- Hydraulic, heavy-duty vises
- Raised table support for material loading
- Precise material alignment
- Braking flywheels
- Dry cut

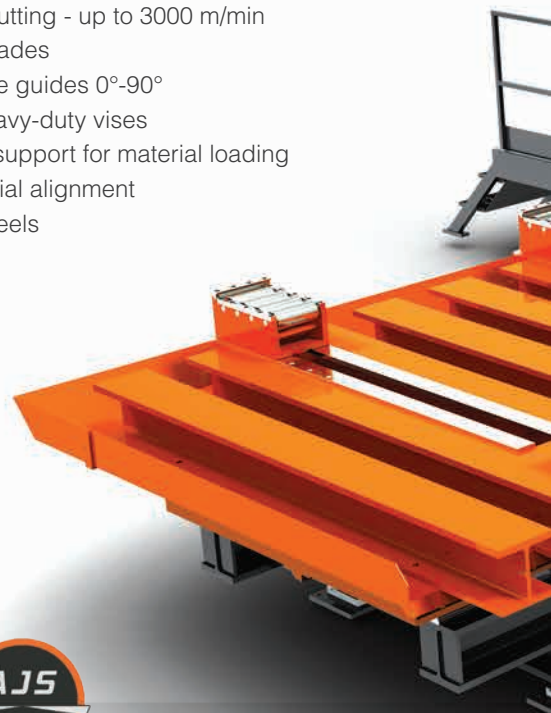
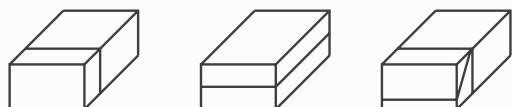

2MF TS HS

2100X1100X4000

2600X1100X4000

CAPACITÀ DI TAGLIO / CUTTING CAPACITY	2100x1100 mm	2600x1100 mm
CORSA TAVOLA / TABLE STROKE	4000 mm	4000 mm
DIMENSIONE LAMA / BLADE DIMENSION	16760x54x1,6 mm	17740x54x1,6 mm
VELOCITÀ LAMA / BLADE SPEED	300÷3000 m/min	300÷3000 m/min
POTENZA MOTORE LAMA / BLADE MOTOR POWER	54 kw	54 kw
PESO / WEIGHT	27500 kg	29500 kg



GANTRY HS

Segatrice a tavola fissa e portale mobile ideata per il taglio di pezzi molto pesanti e di grandi dimensioni. Permette il taglio verticale, orizzontale ed obliquo per operare correttamente nel taglio di lingotti e pezzi forgiati come pure grossi blocchi di alluminio.

La flessibilità data dalla combinazione tra portale mobile, guida-lama rotante e tavola rotante a 360°, permette di eseguire fino a 9 tagli senza riposizionare il materiale.

The Gantry features a fixed table and moving head designed for cutting very large, heavy material. This machine allows for vertical, horizontal, and angle cuts without having to move the material; ideal for ingots and forgings as well as large blocks of aluminum. Typical use would be to cut strips from large blocks, to rough out holds to vastly reduce machining time, and most recently rough out frac blocks prior to machining. The flexibility of the moving head and rotating blade guides, along with the 360 turntable, you can easily make up to 9 cuts with a single set-up.

HIGH LIGHTS

- Ottima finitura di taglio
- Tolleranze precise
- Alta velocità di taglio
- Lame carbide
- Guida-lama rotante 0-90
- Sistema di serraggio materiale
- Allineamento preciso
- Supporto rialzato per carico materiale
- Sistema frenatura volani
- Dry cut
- Tavola rotante
- Excellent cut piece
- Tight tolerances
- High speed cutting
- Hard metal blades
- Rotating blade guides 0-90
- Hydraulic, heavy-duty vises
- Precise material alignment
- Raised table support for material loading
- Braking flywheels
- Dry cut
- Rotating table

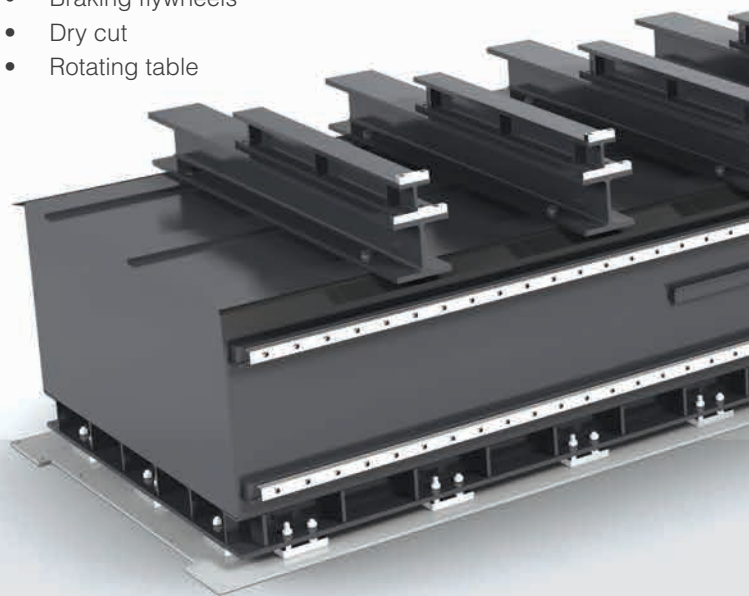
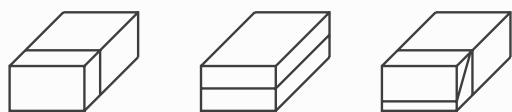

GANTRY HS

2100X1100X4000

2600X1100X4000

CAPACITÀ DI TAGLIO / CUTTING CAPACITY	2100x1100 mm	2600x1100 mm
CORSA TAVOLA / TABLE STROKE	4000 mm	4000 mm
DIMENSIONE LAMA / BLADE DIMENSION	16760x54x1,6 mm	19400x54x1,6 mm
VELOCITÀ LAMA / BLADE SPEED	300÷3000 m/min	300÷3000 m/min
POTENZA MOTORE LAMA / BLADE MOTOR POWER	51 kw	51 kw
PESO / WEIGHT	29000 kg	34000 kg



2MF COILS





Segatrice a tavola mobile ideata per il taglio di COILS.
 Grazie alla speciale tavola, appositamente studiata, permette un facile posizionamento e staffaggio del materiale.
 Il collaudato sistema di lubrificazione minimale, mantiene asciutto il materiale e impedisce il deposito di residui di olio.

Sliding table machine designed for coils cutting.
 Thanks to the special panel, specially designed, allows for easy positioning and clamping of the material.
 The patented minimal lubrication, keep dry the material and prevents the deposit of oil residues.

HIGH LIGHTS

- Ottima finitura di taglio
- Tolleranze precise
- Sistema di serraggio materiale
- Allineamento preciso
- Supporto rialzato per carico materiale
- Taglio asciutto
- Excellent cut piece
- Tight tolerances
- Hydraulic, heavy-duty vises
- Precise material alignment
- Raised table support for material loading
- Dry cut



2MF TM COILS E GRAFITE

2000X2000X3000

CAPACITÀ DI TAGLIO / CUTTING CAPACIT	2000x2000 mm
CORSA TAVOLA / TABLE STROKE	3000 mm
DIMENSIONE LAMA / BLADE DIMENSION	14620x54x1,6 mm
VELOCITÀ LAMA / BLADE SPEED	300÷600 m/min
POTENZA MOTORE LAMA / BLADE MOTOR POWER	18,5 kw
PESO / WEIGHT	27.000 kg

Service e spare parts

La nostra missione, fin dalla progettazione e produzione degli impianti, è **soddisfare le esigenze e necessità di ogni singolo cliente**.

Il **servizio di assistenza efficace e tempestivo**, professionalmente preparato, è sempre disponibile al confronto, con un approccio fortemente orientato alla **risoluzione del problema rapida ed efficace**.

- Tecnici specializzati interni
- Supporto da rete di centri autorizzati
- Copertura capillare e tempestiva sui cinque continenti
- Magazzino ricambi automatizzato
- Assistenza telefonica continuativa
- Servizio di tele-assistenza
- Diagnostica e/o intervento diretto dalla sede
- Manutenzione Preventiva Programmata



Our main mission, from the design and manufacture of plant, is to **satisfy the needs and requirements of each Customer**. An **effective and timely service**, professionally trained, is always available to compare with an approach that is strongly oriented towards quick and comprehensive **resolution of any technical problems**.

- Internal specialized technicians
- Authorized service centers support
- World-wide service
- Automatic spare parts warehouse
- Ongoing telephone support
- Remote service
- Direct diagnostic and/or direct intervention from head quarter
- Preventive Maintenance Schedule

New HMI system Always connected



- Connessione Wi-fi per assistenza tecnica
- E-mail Alarm system
- Mobile remote control da dispositivi mobile e smartphone con App dedicata
- Video-controllo dedicato per assistenza real time
- MES ready - connessione con rete aziendale per scambio dati
- Database integrato con parametri di taglio per lame bi-metalliche e metallo duro
- Backup programmabile su scheda SD e USB
- Connessione stampante

- Wi-fi connection for remote technical assistance
- E-mail alarm system
- Remote access via smart phone with dedicated APP
- Real time technical service with video control
- MES ready - can be hooked up to office network for data collection
- Database for machine program recall to minimize operator error - once program set up operator need only to choose program and machine will set own feeds and speeds
- Backup via SD card or USB
- Can connect printer

COMPLETE CUTTING TECHNOLOGIES

Fully designed and built in Italy



WATER-JET

Innovazione e flessibilità per il taglio a freddo della nostra Waterjet, qualità e precisione per ogni applicazione, materiale e geometria.

Innovation and flexibility for the cold cutting of our Waterjet, high quality and performances for any kind of materials, application fields and geometries.



DUALINE



PLASMA



FLAME

Al vostro fianco per ogni esigenza di taglio
At your side for any cutting application

FRIGGI
SOTAAB

www.friggics.com

SOTAAB[®]

www.soitaab.com



FRIGGI
SOITAAB®

SOITAAB IMPIANTI SRL

via del Lavoro, 9
20061 - Carugate (Mi)
ITALY

T +39 02 92504044

F +39 02 92150095

www.friggics.com

www.soitaab.com

bandsaws@soitaab.com

SOITAAB®
Cutting at the highest levels